

Driver's Seat

KFS10



The Driver's Seat KFS10 is ergonomically designed and provides a high grade of comfort. The Driver's Seat has a pneumatic vibration absorption system with weight adjustment by compressor (24V DC 8 Ampere) and a standard seat cushion V-cut. Through its three horizontal adjustment, it can be flexibly adapted to very many applications. All adjustment controls are positioned ergonomically within easy access. The metal parts are protected against corrosion and painted black.

Technical data:

Suspension stroke	80 mm
Weight adjustment	50 - 150 kg (pneumatic) 50 - 130 kg (mechanical)
Horizontal adjustment	
Seat with suspension system	160 mm
Seat part individual	240 mm
Seat cushion	160 mm
Inclination of the backrest	Max. 90°
Height and slope adjustment	40 mm



Example

		KFS102	-A1	-L2	-S2	-R1
Basic unit						
KFS101	Driver's Seat with air-permeable artificial leather cover black with V-cut					
KFS102	Driver's Seat with textile cover black with V-cut					
Attachments						
K	Headrest					
A1	Armrest adjustable (2 pieces) 50 mm wide					
A2	Armrest continuously adjustable (2 pieces) 100 mm wide					
L1	Lumbar support manual adjustment - 2 movement					
L2	Lumbar support manual adjustment - 4 movement					
B	Seat allocation recognition					
H	Seat cushion and backrest with heating element 24 V DC 47W					
S1	Safety belt 2 point fixing (automatic)					
S2	Safety belt 4 point fixing (headrest required)					
S3	Safety belt 2 point fixing (static)					
U	Console (base)					
C3	Loose cover for Driver's Seat KFS10 with V-cut					
R1	Price reduction pneumatic vibration absorption system					
R2	Seat cushion without V-cut					

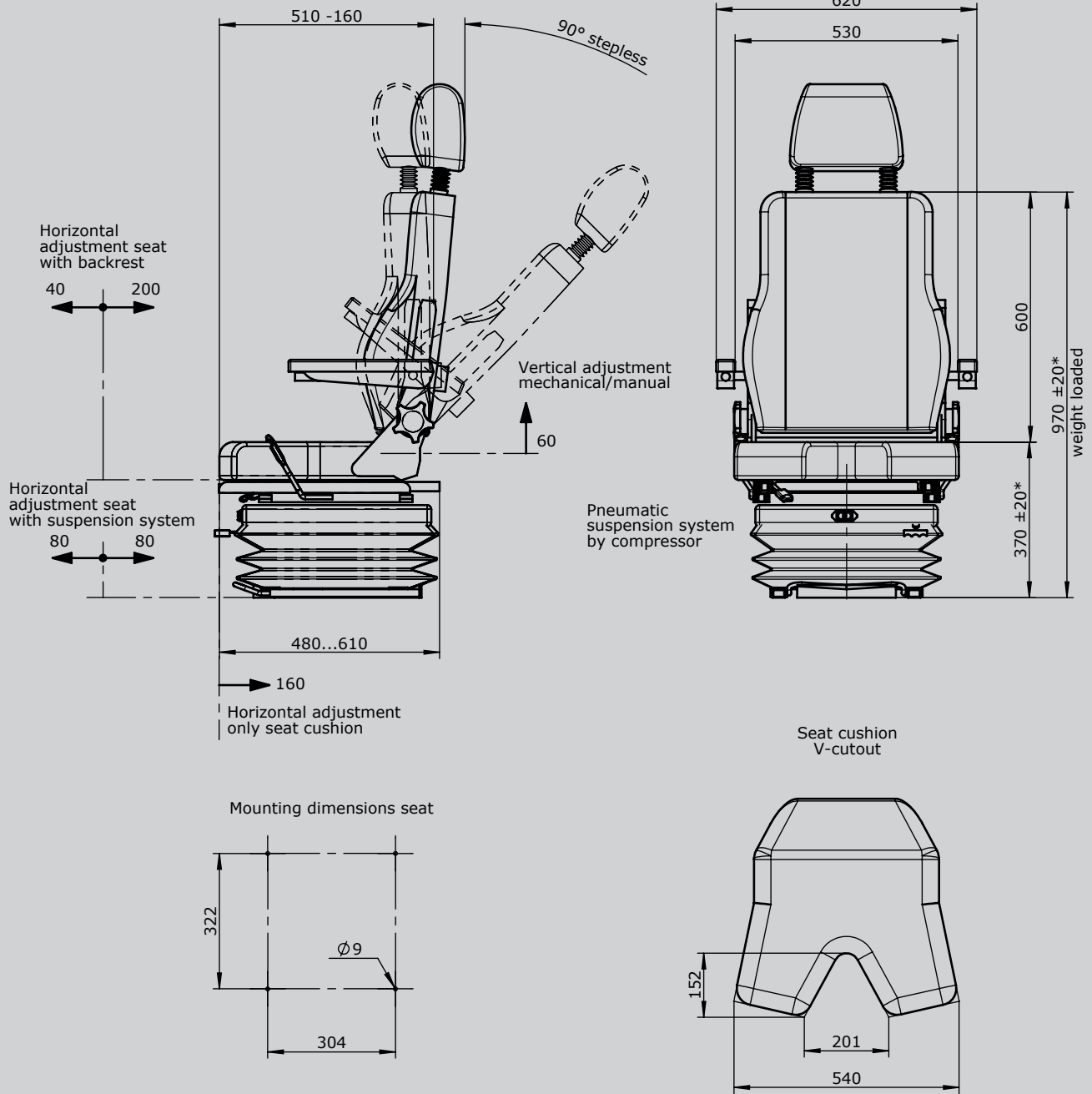

* adjustable