



The Control-Switch N9 is a rugged switching device for electrohydraulic and hoisting applications. The modular design enables the switching device to be used universally.

Technical data

Mechanical life N9	10 million operating cycles
Operating temperature	-40°C to +85°C
Degree of protection	IP54



		N9	Example -2 R P	-A05	P134	-X
Basic unit						
N9	Control switch with twist grip					
Axis 1: direction 3-4						
1	1 contact	Standard contact - arrangement see page 127				
2	2 contacts	z.B. A98 MS0 A05 MS21 A99 contacts - arrangement according customer request				
R	Friction brake (included in basic unit)					
(P)	Possibility of mounting potentiometer and encoder (Gessmann-types)					
P	Potentiometer	P131	T396 2 x 0,5 kOhm	I max. 1 mA		
		P132	T396 2 x 1 kOhm	I max. 1 mA		
		P133	T396 2 x 2 kOhm	I max. 1 mA		
		P134	T396 2 x 5 kOhm	I max. 1 mA		
		P135	T396 2 x 10 kOhm	I max. 1 mA		
		More potentiometers on request!				
H	Hall-Potentiometer	E14811	0,5...2,5...4,5 V / 4,5...2,5...0,5 V			
Special model						
X	Special / customer specified					

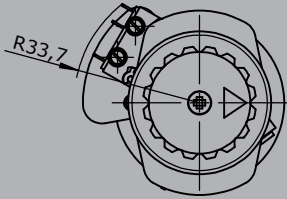
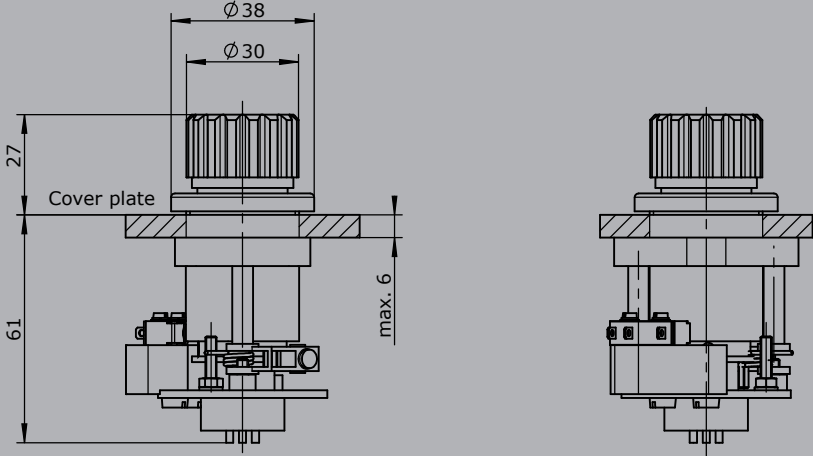

Hole pattern

