



Type KFS62-2-5-6-24

The crane driver's seat KFS 6 is ergonomically designed and provides a high grade of comfort.

The driver's seat is a low level mechanical suspension seat with an oilhydraulic vibration absorption system with weight adjustment.

All adjustment controls are positioned ergonomically within easy access.

For this comfort driver's seat KFS 6 a lot of efficient accessories are available look Pos. 5-25.

The metal parts are protected against corrosion and painted black.

Technical detail:

Suspension stroke	95 mm
Weight adjustment	40-130 kg
Horizontal adjustment	180 mm
Backrest adjustment, fine control inclination backwards	28° (90°)
Height and slope adjustment	65 mm

Pos.				Weight kg	Type	Price EURO
1	Driver's seat standard design with air-permeable artificial leather cover black			25	KFS 61	
2	Driver's seat standard design with textil cover grey / yellow			25	KFS 62	
3						
4						
5	Headrest raint					
6	Armrest fully adjustable (2 pieces) 50 mm wide					
7	Armrest fully adjustable (2 pieces) 100 mm wide					
8	Backrest high + 100 mm inclination backwards max. 90°					
9	Backrest standard with lumbar support manual adjustment					
10						
11	Seat cushion deep adjustment mechanical 60 mm					
12						
13	Seat contact 1 NO 1,5 A 24 V DC					
14	Seat cushion and backrest standard with heating element 24 V DC 42 Watt					
15						
16	Safety belt 2 point fixing					
17	Safety belt 4 point fixing (trouser braces belt) (Pos. 5 additionally required)					
18						
19						
20						
21						
22						
23						
24	Console			10		
25						

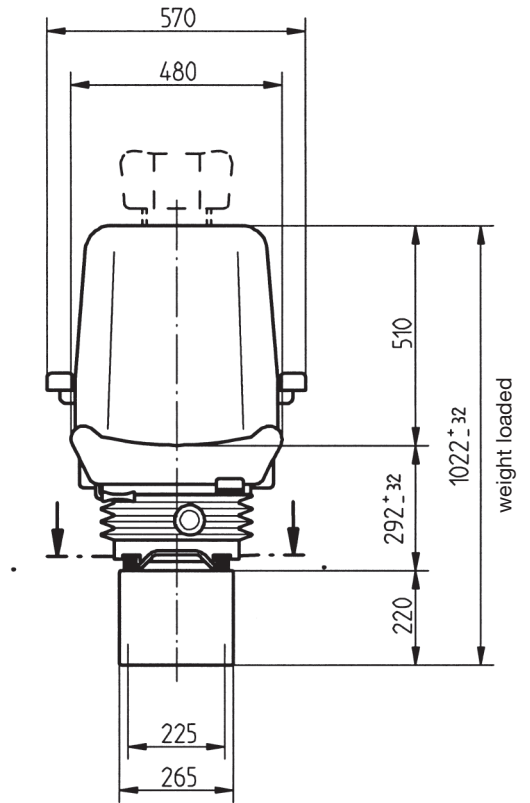
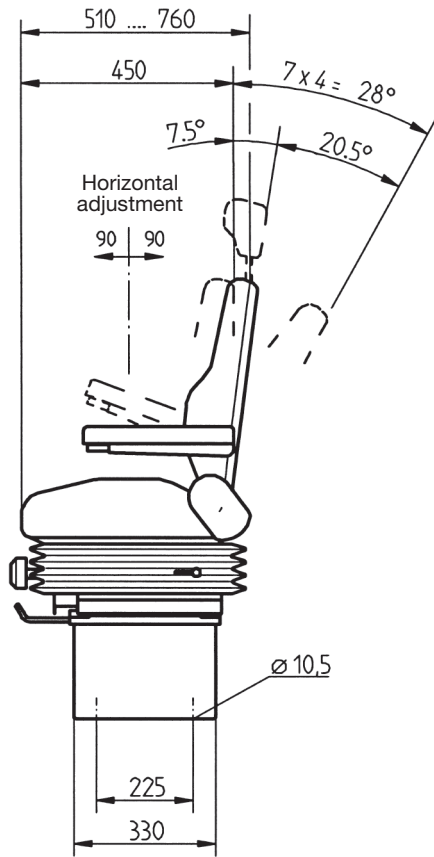

seat slide fastener dimension

