



Type KST181KFS92-...

The swivelling crane control unit KST 18 is ergonomically designed and provides a high grade of comfort.

The standard design includes following:

Equipment boxes: Sheet steel. The top panel of the equipment box with the devices can be raised and locked in position and is provided with armrests. Cabling is run through duct from the equipment boxes in the cross-member. (Terminal block).

Seat: Comfortable spring mounted seat KFS 9, with an oilhydraulic vibration absorption system, weight adjustment and airpermeable artificial leather or textil material, with headrest.

Manual adjustments: Seat horizontally and vertically. Inclination of cushion, backrest and armrest also adjustable. Weight setting for optimum spring suspension. Equipment boxes horizontally and vertically.

Motorized adjustments: Seat with equipment boxes vertical (inclinations adjustments forward/backward). Seat with equipment boxes horizontal. Selector switches for motorized-drives are in the equipment box. Motor 24 V DC ca. 15 ampere.

Cross-member: Steel section, top of which can be raised to lay cabling. The seat with the boxes can be tilted forwards so that the cable duct in the cross-member is accessible.

Swivel base: Zero-end-float spring-loaded bearing. Rotational movement 180° right, 90° left, stopped by friction brake.

Surface treatment: Anti-corrosion primer, top coat: 2 coats of epoxy-resin paint, standard colour RAL 7032 pebble-grey. textured varnish
All non-painted metal parts are electrogalvanized and chromed.

Description data see catalog 5/003/004

Permissible ambient temperature	Operation -40° C to +60° C
	Storage -50° C to +80° C
Climate resistance	
Damp heat constant	DIN IEC 68 part 2-3
Damp heat cyclic	DIN IEC 68 part 2-30
Degree of protection	IP 54 IEC 529 DIN 40050

Pos.				Weight kg	Type	Price EURO
1	Crane control unit standard design	Equipment boxes 160 x 420 mm		148	KST 181	
2	Crane control unit standard design	Equipment boxes 200 x 420 mm		150	KST 182	
3						
4						
5	Crane control unit standard design	Equipment boxes special dimensions			KST 18x	
6	additional variations for driver's seat KFS 6	see catalog 2/134			KFS 6	
7	Driver's seat KFS 9	see catalog 2/140			KFS 9	
8						
9						
10	Footrest (required) mounted onto swivel base adjustable ± 30 mm			8		
11						
12						
13	Plate for horizontal manual adjustment of control unit adjustable ± 250 mm			95		
14						
15						
16						
17						
18	Motorized adjustment of control unit swivelling (drive 24 V DC, seat height + 30 mm)			16		
19	Heating 2 x 2 kW with ventilator 230 V 50 Hz airvolume ca. 300 m³/h mounted on the swivel base sidewise					
20	Multi-axis controller	see catalog 1/100				
21	Single-axis controller	see catalog 1/200				
22	Double-handle controller	see catalog 1/160				
23	Control-switch	see catalog 1/220				
24	Command and indicating devices	see catalog 1/360				
30	Terminal block 4 mm² without wiring each terminal				KL	
31	Terminal block 4 mm² with wiring wire 1,5 mm² each terminal				KL	
32	External wiring single wire highly flexible 1,5 mm² 5 metre long					
33	Additional or subtract price each metre					
40	Special painted					
41	Indicating labels not engraved with 2 or 4 arrows					
42	Engraving, each 10 characters					

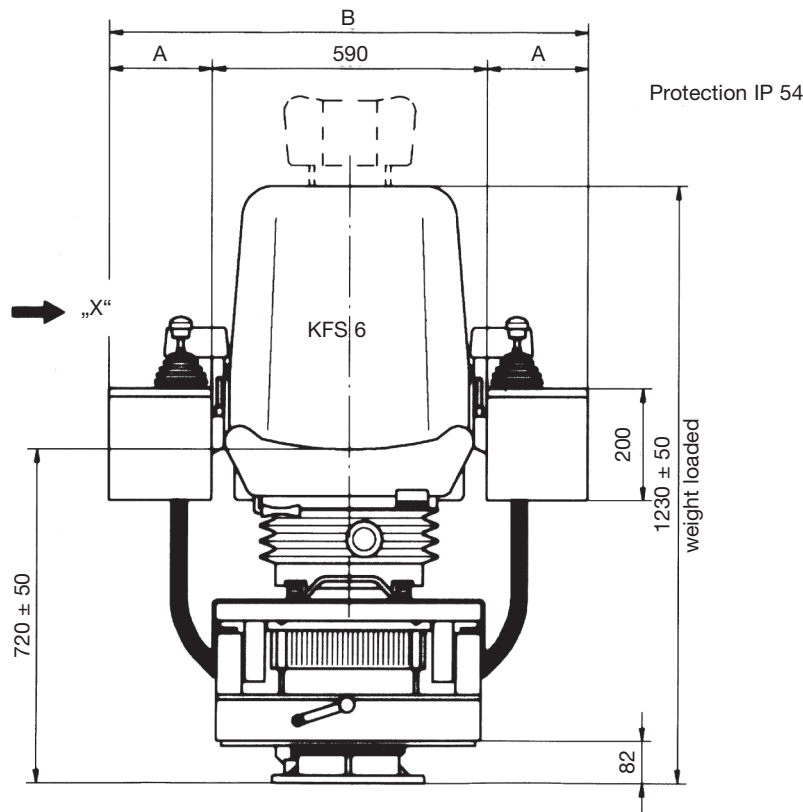

Type	Dimension A	Dimension B	Dimension C
KST 181	160	910	<625 >815
KST 182	200	990	<655 >835

