



Type KST51KFS92-...

The swivelling crane control unit KST 5 is ergonomically designed and provides a high degree of comfort.

The standard design includes following:

Equipment boxes: Sheet steel. The top panel of the equipment boxes with the devices can be raised and locked in position. The terminal strip is easily accessible via an opening on the inside that can be closed with a lockable cover.

Seat: Comfortable spring mounted seat KFS 6, with an oilhydraulic vibration absorption system, weight adjustment and air-permeable artificial leather or textil material, with headrest, with armrests.

Adjusting possibilities: Seat horizontally and vertically. Inclination of cushion, backrest and armrest also adjustable. Weight setting for optimum spring suspension.

Cross-member: Steel section, top of which can be raised to lay cabling. The seat can be tilted backwards so that the cable duct in the cross-member is accessible.

Swivel base: Zero-end-float spring-loaded bearing. Rotational movement 180° right, 90° left, stopped by friction brake.

Surface treatment: Anti-corrosion primer, top coat: 2 coats of epoxy-resin paint, standard colour RAL 7032 pebble-grey, textured varnish
All non-painted metal parts are electrogalvanized and chromed.

Permissible ambient temperature	Operation -40° C to +60° C
	Storage -50° C to +80° C
Climate resistance	
Damp heat constant	DIN IEC 68 part 2-3
Damp heat cyclic	DIN IEC 68 part 2-30
Degree of protection	IP 54 IEC 529 DIN 40050

Description data see catalog 5/003/004

Pos.				Weight kg	Type	Price EURO
1	Crane control unit standard design	Equipment boxes 200 x 580 mm		84	KST 51	
2	Crane control unit standard design	Equipment boxes 270 x 580 mm		88	KST 52	
3						
4	Crane control unit standard design	Equipment boxes 320 x 580 mm		92	KST 54	
5	Crane control unit standard design	Equipment boxes special dimensions			KST 5x	
6	additional variations for driver's seat KFS 6 see catalog 2/134				KFS 6	
7	Driver's seat KFS 9	see catalog 2/140			KFS 9	
8	Driver's seat KFS 10	see catalog 2/142			KFS 10	
9	Monitor mounting support left or right T 478			10		
10	Footrest mounted onto swivel base adjustable ± 30 mm			8		
11						
12	Manual adjustment of equipment boxes horizontal adjustable ± 75 mm					
13	Plate for horizontal manual adjustment of control unit adjustable ± 250 mm			95		
14	Manual adjustment of control unit vertical (gas loaded spring) adjustable 80 mm			25		
15						
16						
17						
18	Motorized adjustment of control unit swivelling (drive 24 V DC seat height + 30 mm)			8		
19	Heating 2 x 2 kW with ventilator 230 V 50 Hz airvolume ca. 300 m³/h mounted on the swivel base sidewise					
20	Multi-axis controller	see catalog 1/100				
21	Single-axis controller	see catalog 1/200				
22	Double-handle controller	see catalog 1/160				
23	Control-switch	see catalog 1/220				
24	Command and indicating devices	see catalog 1/360				
30	Terminal block 4 mm² without wiring each terminal				KL	
31	Terminal block 4 mm² with wiring wire 1,5 mm² each terminal				KL	
32	External wiring single wire highly flexible 1,5 mm² 5 metre long					
33	Additional or subtract price each metre					
40	Special painted					
41	Indicating labels not engraved with 2 or 4 arrows					
42	Engraving, each 10 characters					

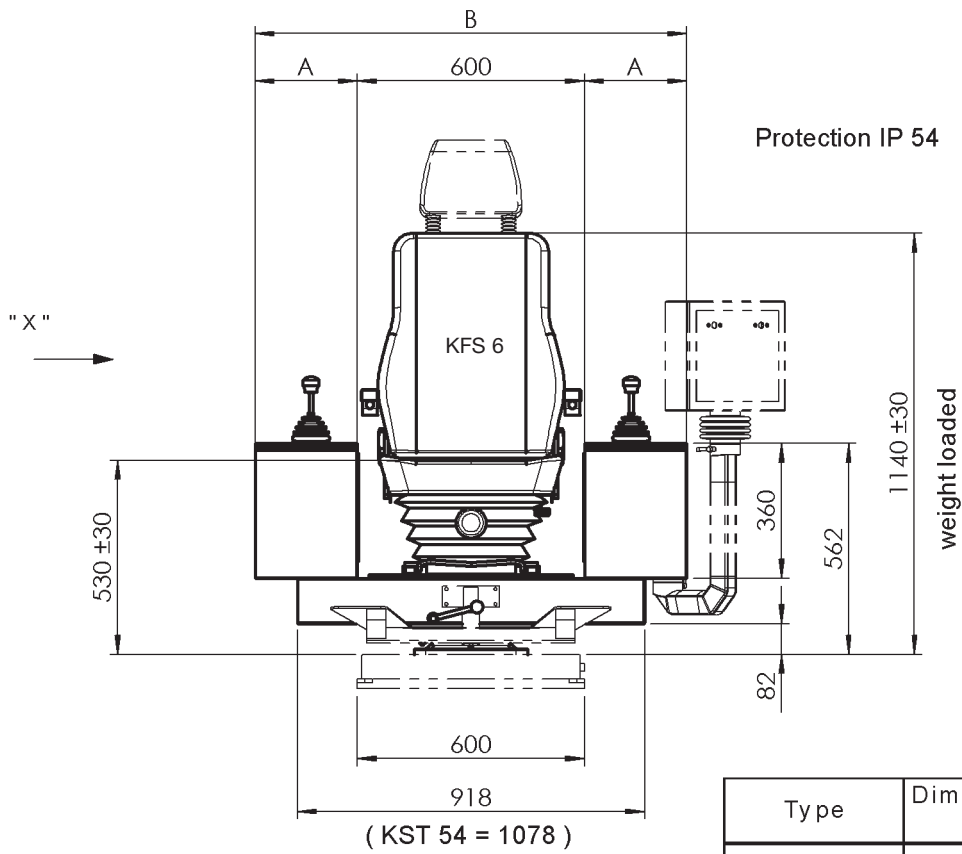

Type	Dimension A	Dimension B	Dimension C
KST 51	200	1000	580
KST 52	270	1140	640
KST 54	320	1240	690

