



Type V10L-01ZP+01ZP-...

The multi-axis controller V 10 is a rugged switching device according IEC 947-5-1 EN 60947 DIN VDE 0660-200 for remote control and electro-hydraulic applications. The V 10 is resistant to oil, maritime climate, ozone and UV radiation.

Contact complement 0,5 A 110 V AC 15 res. 1,5 A 24 V DC 13
I min > 0,2 mA 2 V DC 12 Gold plated for max. load of 0,12 Watt (standard)

Mechanical life 8 million (operating cycles)
Permissible ambient temperature Operation -40° C to +60° C
Storage -50° C to +80° C

Climate resistance
Damp heat constant DIN IEC 68 part 2-3
Damp heat cyclic DIN IEC 68 part 2-30
Degree of protection front IP 54 IEC 529 DIN 40050

Technical data see catalog 5/100
Description data see catalog 5/002

Spindle block with schematic representation of the master controller installation and deflection directions. Version shown for left-hand side installation (right-hand side installation is mirror image).

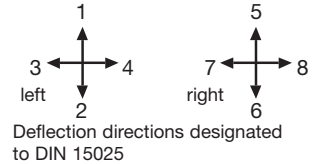

Pos.	V 10.1	V 10	Type expansion		Weight gramm	Type	Price EURO	
1					200	V 10.1		
2								
3						250	V 10	
4								
5								
7.1	Multi-axis controller left	(dir. 1-2, 3-4)				L		
7.2	Multi-axis controller right	(dir. 5-6, 7-8)				R		
10	Gate cross-shaped	(prohibits diagonal shifting)			20	P		
11	Gate special-shaped	(e.g. H-gate)			20	PX		
20	Control-handle with knob solid							
21	Control-handle with latch for mechanical zero interlock by lifting				50	M		
21.1	Control-handle with dead man's button 1 NO				80	T		
22								
23								
24								
25								
26	Control-handle with palm grip B 5				40	B 5		
27	Control-handle with palm grip B 5 with push button top 1 NO				60	B 5D		
28								
29	More knobs, grips and T-grips with and without signal devices see catalog 1/280...							
30	Masterswitch (contact) without switching sequence			No. of contacts 2	20	01		
31				4	40	02		
32	Direction 1-2 and 3-4 each 1 masterswitch			6	60	03		
33	Switching program according contact-arrangement MS... see catalog 5/001 or to your contact-arrangement		A...					
34								
35								
36	Switching sequence 4-0-4							
38	Spring return in 0-position	(included in the spindle block)				Z		
39	Friction brake adjustable	(for each direction)				R		
40	Potentiometer e.t.c. each masterswitch with mounted Conductive-plastic potentiometer T 320, with centre tap linear 0,5 Watt wiper current max. 1 mA resistance 2 x 1k \cong P252, 2 x 5k \cong P254		...P25 \square		20	P		
41								
42								
43	more Potentiometer e.t.c. see catalog 1/240...		P...					
45	Electronic (Amplifier, Profi-Bus, CAN-Bus) see catalog 3/510/...		E...					
50	Plastic housing I 122 x 120				350	I		
51								
52	More housing see catalog 1/350							
60	Indicating labels not engraved with 2 or 4 arrows							
61	Engraving, each 10 characters							
70	Command and indicating devices see catalog 1/360							



Knob solid

T = dead man's button

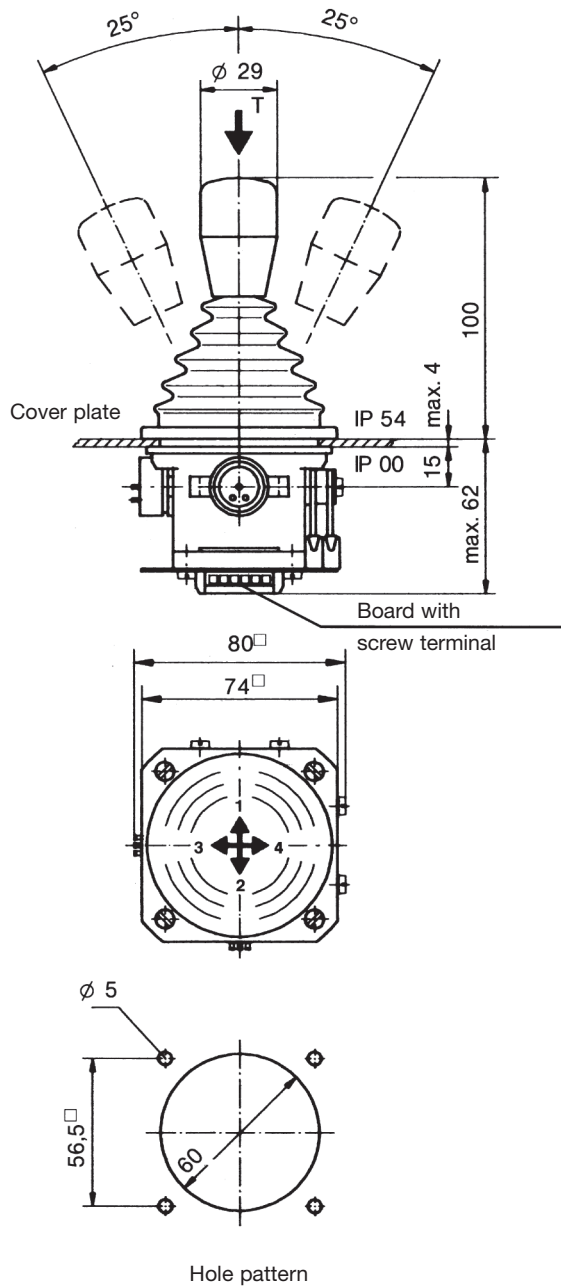

Ball grip

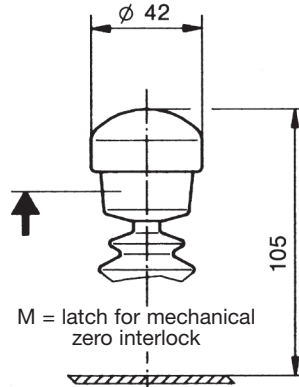

Palm grip B 5

