



Type V25LT-2ZS+2ZS-B...

The multi-axis controller V 25 is a rugged switching device according IEC 947-5-1 EN 60947 DIN VDE 0660-200 for electro-hydraulic applications. The modular design enables the switching device to be used universally. The V 25 is resistant to oil, maritime climate, ozone and UV radiation.

Contact complement 0,5 A 110 V AC 15 res. 1,5 A 24 V DC 13
I min > 0,2 mA 2 V DC 12 Gold plated for max. load of 0,12 Watt (standard)

Mechanical life V 25 8 million (operating cycles)
Permissible ambient temperature Operation -40° C to +60° C
Storage -50° C to +80° C
Climate resistance
Damp heat constant DIN IEC 68 part 2-3
Damp heat cyclic DIN IEC 68 part 2-30
Degree of protection front IP 54 IEC 529 DIN 40050
Technical data see catalog 5/100
Description data see catalog 5/002

Spindle block with schematic representation of the master controller installation and deflection directions.
Version shown for left-hand side installation (right-hand side installation is mirror image).

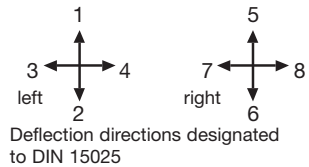

Pos.	V 25.1	V 25	Type expansion	Weight gramm	Type	Price EURO
1				500	V 25.1	
2						
3				500	V 25	
4						
5						
7.1	Multi-axis controller left	(dir. 1-2, 3-4)			L	
7.2	Multi-axis controller right	(dir. 5-6, 7-8)			R	
10	Gate cross-shaped	(prohibits diagonal shifting)		60	P	
11	Gate special-shaped	(e.g. H-gate)		60	PX	
20	Control-handle with knob solid					
21	Control-handle with latch for mechanical zero interlock by lifting			50	M	
22	Control-handle with dead man's button 1 NO			100	T	
23	Control-handle with signal button 1 NO			100	H	
24	Control-handle with push button 1 NO			110	D	
25	Control-handle with flat push button 1 NO			110	DV	
26	Control-handle with palm grip B 1			40	B 1	
27	Control-handle with palm grip B 1 with push button top 1 NO			60	B 1T	
28	Control-handle long or short					
28.1		+20 mm				
29	More knobs, grips and T-grips with and without signal devices see catalog 1/280...				S8	
30	Masterswitch (contact) switching sequenc -0-		No. of contacts	1	1	
31				2	2	
32	Direction 1-2 and 3-4 each 1 masterswitch					
33	Switching program according contact-arrangement MS... see catalog 5/001		A...			
34	or to your contact-arrangement					
38	Spring return in 0-position	(included in the spindle block)		30	Z	
40	Potentiometer e.t.c. each masterswitch with mounted Magnet KEM for redundant Hallsensors			70	S	
42	Voltage output impressed 0,5-2,5-4,5 Volt electronic for 1 axis		EU 15			
43	electronic for 2 axis		EU 16			
	Technical data: Power supply 4,6-5,5 Volt output 0,5-2,5-4,5 Volt + 5 mA, output characteristic Linear					
45	more Electronic (Amplifier, Profi-Bus, CAN-Bus) see catalog 3/510/...					
50	Cover housing		E...	300	B	
51	Filter plug M 20 for air-condition			20		
52	Cable entry M 20 with anti-kink protection and strain relief			30		
53	Plug in socket 9-pole female insert D-SUB9 wired			150		
54	Connector 9-pole male insert D-SUB9 unwired			150		
55	Wiring plug in socket or connector each wired-connection					
60	Indicating labels not engraved with 2 or 4 arrows					
61	Engraving, each 10 characters					



T = dead man's button
H = signal button
M = latch for mechanical zero interlock

Knob solid
D = -push button

Palm grip B 1
B 1T = dead man's button
see catalog 1/283

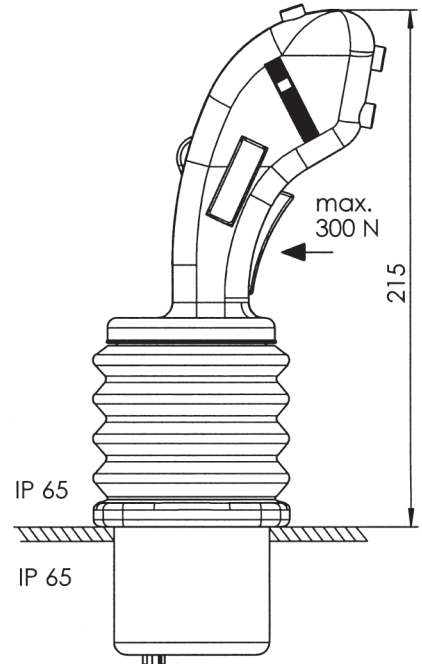
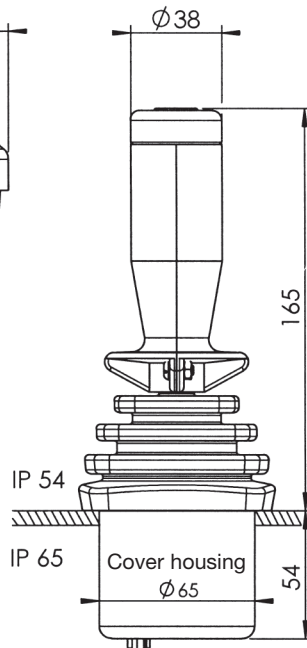
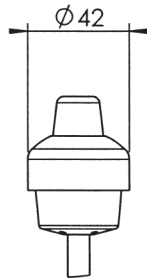
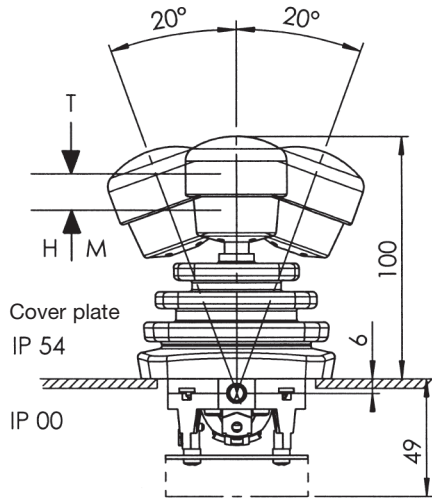

Palm grip B 3
see catalog 1/286
for the 3. direction 11-12
for the 4. direction 13-14

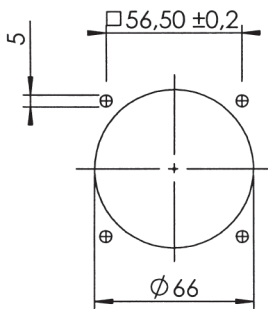
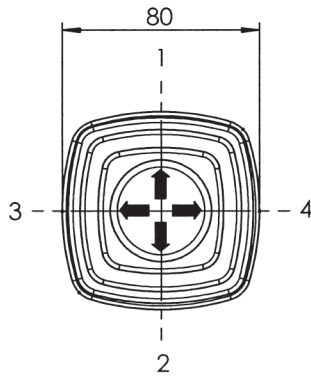

Hole pattern

↑
A

View A

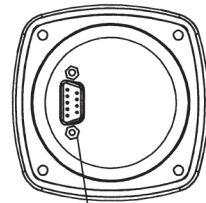

Plug in socket D-SUB9

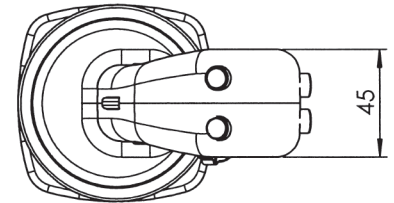

	V25	L	S5	P	D - 2	Z	S + 2	Z	S	-B-	-X-	A05	EU16
multi-axis controller													
installation side L o. R													
special control handle													
gate													
handle													
contact dir. 1-2 (5-6)													
spring return dir. 1-2 (5-6)													
hallsensor dir. 1-2 (5-6)													
contact dir. 3-4 (7-8)													

electronic description
dir. 1-2 (5-6) + dir. 3-4 (7-8)
see p. 1/240ff
Arrangement dir. 1-2 (5-6) +
dir. 3-4 (7-8) see p. 5/001
special please describe
housing
hallsensor dir. 3-4 (7-8)
spring return dir. 3-4 (7-8)