

Type V62L-03ZP+03Z-...

The multi-axis controller V 6 is a rugged switching device according IEC 947-5-1 EN 60947 DIN VDE 0660-200 for hoisting applications. The modular design enables the switching device to be used universally. The V 6 is resistant to oil, maritime climate, ozone and UV radiation.

Contact complement 2 A 250 V AC 15 res. 1 A 24 V DC 13 (standard) or 4 A 250 V AC 15 (special)

Mechanical life 10 million (operating cycles)
Permissible ambient temperature Operation -40° C to +60° C
Storage -50° C to +80° C

Climate resistance
Damp heat constant DIN IEC 68 part 2-3
Damp heat cyclic DIN IEC 68 part 2-30
Degree of protection front IP 54 IEC 529 DIN 40050
Technical data see catalog 5/100
Description data see catalog 5/002

Spindle block with schematic representation of the master controller installation and deflection directions.
Version shown for left-hand side installation (right-hand side installation is mirror image).

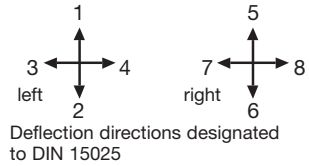

Pos.	V 61	V 61.1	V 62	V 64	V 64.1	Type expansion		Weight gramm	Type	Price EURO
1								960	V 61	
2								980	V 61.1	
3								980	V 62	
4								1010	V 64	
5								960	V 64.1	
7.1	Multi-axis controller left		(dir. 1-2, 3-4)						L	
7.2	Multi-axis controller right		(dir. 5-6, 7-8)						R	
10	Gate cross-shaped		(prohibits diagonal shifting)					60	P	
11	Gate special-shaped		(e.g. H-gate)					60	PX	
20	Control-handle with knob solid									
21	Control-handle with latch for mechanical zero interlock									
21.1	by lifting							50	M	
21.2	by lifting, interlocking the gate or the joint bracket							60	MP	
21.3	by pushing down							50	MN	
21.4	Mechanical zero interlock with command devices see catalog 1/282									
22	Control-handle with dead man's button 1 NO							100	T	
23	Control-handle with signal button 1 NO							100	H	
24	Control-handle with push button 1 NO							110	D	
25	Control-handle with flat push button 1 NO							110	DV	
26	Control-handle with palm grip B 1							40	B 1	
27	Control-handle with palm grip B 1 with push button top 1 NO							60	B 1T	
28	Control-handle long or short									
28.1			-40 mm						S3	
28.2			-20 mm						S5	
28.3			+20 mm						S8	
29	More knobs, grips and T-grips with and without signal devices see catalog 1/280...									
30	Masterswitch (contact set) switching sequenc 4-0-4						No. of contacts 2	290	01	
31							4	350	02	
32	Direction 1-2 and 3-4 each 1 masterswitch						6	410	03	
33	Switching program according contact-arrangement MS... see catalog 5/001					A...	8	470	04	
34	or to your contact-arrangement						10	530	05	
35							12	590	06	
36	Switching sequence 5-0-5 or 6-0-6									
37	Micro changeover contact (MZT 1) positive opening						2			
38	Spring return in 0-position (for each direction)							110	Z	
39	Friction brake adjustable (for each direction)							30	R	
40	Potentiometer e.t.c. each masterswitch with mounted Wire-wound potentiometer T 130, with centre tap, 1,5 Watt wiper current max. 10 mA resistance 2 x 0,5k \pm P021, 2 x 1k \pm P022, 2 x 2k \pm P023, 2 x 5k \pm P024, 2 x 10k \pm P025					...P02 \square		70	P	
41	Prepared for mounting potentiometer shaft 6 mm adjusting-angle 2 x 150°								(P)	
42	Prepared for mounting potentiometer e.t.c. adjusting-angle variable.								(P)	
43	more Potentiometer e.t.c. see catalog 1/240...					C..., P...				
50	Steel sheet housing B 200 masterswitch max. size 04							1300	B	
51	Steel sheet housing B 230 x 340 masterswitch max. size 06							1500	B	
52	More housing see catalog 1/350									
60	Indicating labels not engraved with 2 or 4 arrows									
61	Engraving, each 10 characters									
70	Command and indicating devices see catalog 1/360									



T = dead man's button
H = signal button
M = latch for mechanical zero interlock

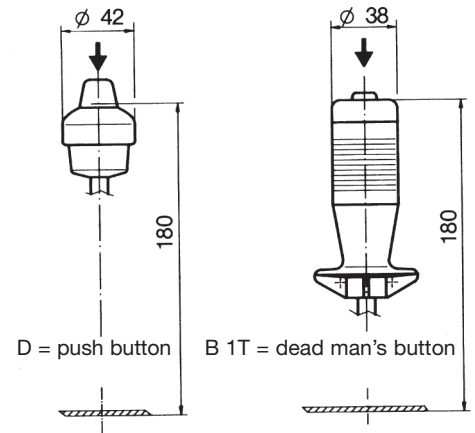
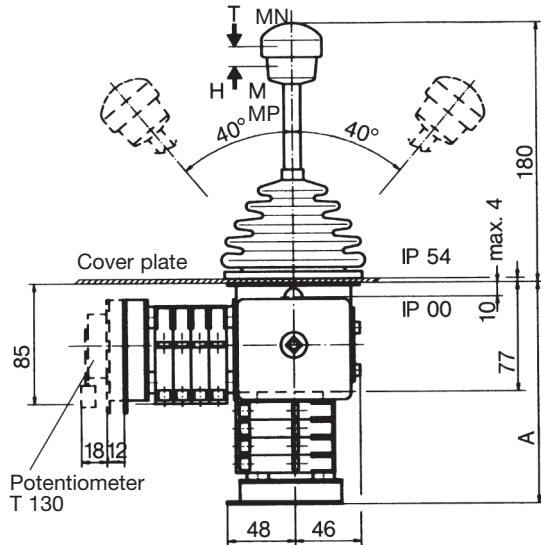

Type	No. of contacts	Dimension A	Dimension B
01	2	119	82
02	4	131	94
03	6	144	107
04	8	156	119
05	10	169	132
06	12	181	144

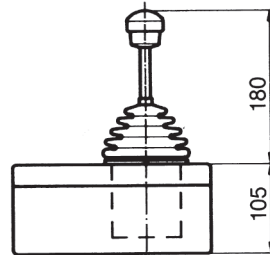
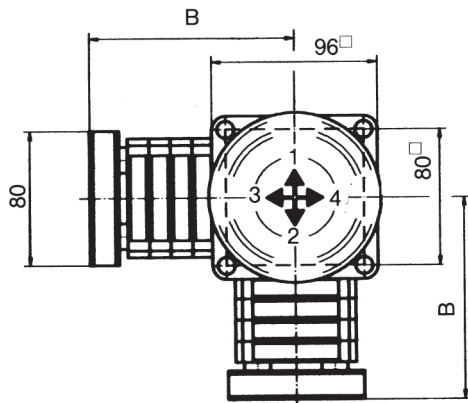

Steel sheet housing

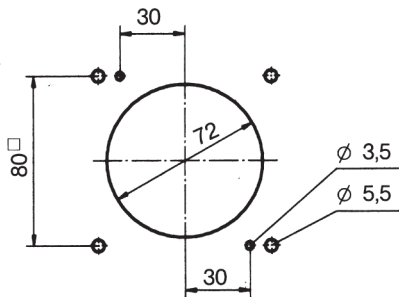

Hole pattern

